

Designing and Testing cdma2000 Mobile Stations

Application Note 1358

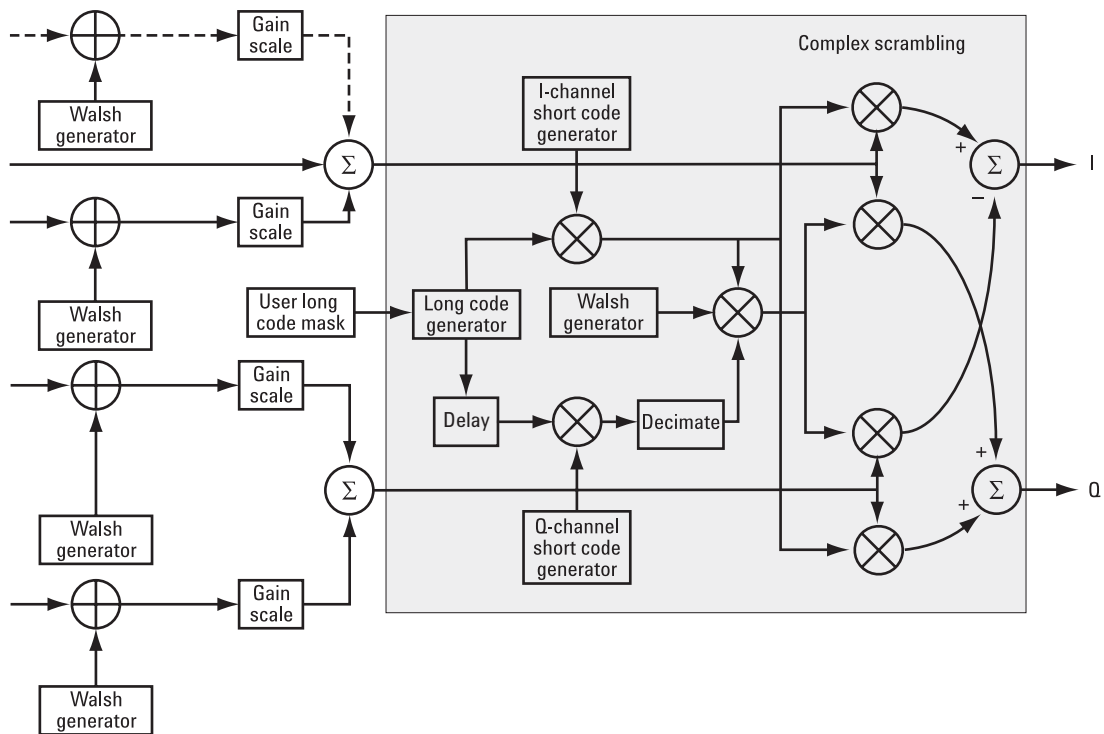

Table of contents

- Introduction3**

- 1 Basic concepts of cdma20004**
 - 1.1 Spreading rate4
 - 1.2 Radio configuration5
 - 1.3 Forward link air interface5
 - 1.4 Reverse link air interface–HPSK6
 - 1.5 Forward link power control8
 - 1.6 Differences between cdma2000 and W-CDMA8

- 2 Design and measurement issues9**
 - 2.1 Maximizing battery life9
 - 2.1.1 CCDF10
 - 2.1.2 ACPR11
 - 2.2 Measuring modulation quality12
 - 2.2.1 QPSK EVM13
 - 2.2.2 Composite rho15
 - 2.2.3 Code domain power19
 - 2.2.4 Symbol EVM23
 - 2.2.5 Symbol power versus time24
 - 2.2.6 Demodulated bits25
 - 2.3 Measuring receiver performance25
 - 2.3.1 Performance tests at variable data rates25
 - 2.3.2 Quasi-orthogonal functions26

- Appendix:**
- Agilent solutions for cdma2000 MS design and test27**

- Acronym glossary31**

- References32**

- Related literature32**

Introduction

One of the technologies meeting the IMT-2000 requirements for a third generation (3G) global wireless communications system is cdma2000, also known as IS-2000¹. The Third-Generation Partnership Project 2 (3GPP2) wrote the specification for this wideband code division multiple access (CDMA) system as a derivative of the IS-95-B CDMA system, also known as cdmaOne. The 3GPP2 organizational partners are the Japanese Association of Radio Industries and Businesses (ARIB), Telecommunication Technology Committee (TTC), Telecommunications Industries Association (TIA), and Korean Telecommunications Technology Association (TTA).

As the IS-2000 standards are finalized, the first mobile station designs are being completed and tested. This application note describes mobile station (MS) design and measurement issues at the physical layer (layer 1) that may differ between cdma2000 and cdmaOne. Although it focuses on the last stages of MS development, it is also useful for engineers working in the early stages of manufacturing. The application note also provides a list of Agilent Technologies' cdma2000 solutions for these topics.

This application note assumes that you are familiar with cdmaOne measurements and technology basics. cdmaOne is used as a reference throughout this application note. The main differences between cdmaOne and cdma2000 systems and the corresponding design and measurement implications are highlighted. For more information on cdmaOne measurements see [1].

This application note can be downloaded from the Agilent Technologies web site and printed locally from this url:
<http://www.agilent.com/find/3G> located under "Technical Papers".

1. IS-2000 is the Telecommunications Industries Association's (TIA's) standard for 3G technology that is an evolution of cdmaOne technology. cdma2000, which is often used interchangeably with IS-2000, is also used to refer to the access format and system.

1 Basic concepts of cdma2000

The main advantages that cdma2000 offers over other IMT-2000 proposals are backward compatibility with cdmaOne systems and a smooth migration from second-generation (2G) cdmaOne systems to 3G. Figure 1 shows the potential evolution path from cdmaOne to cdma2000 systems.

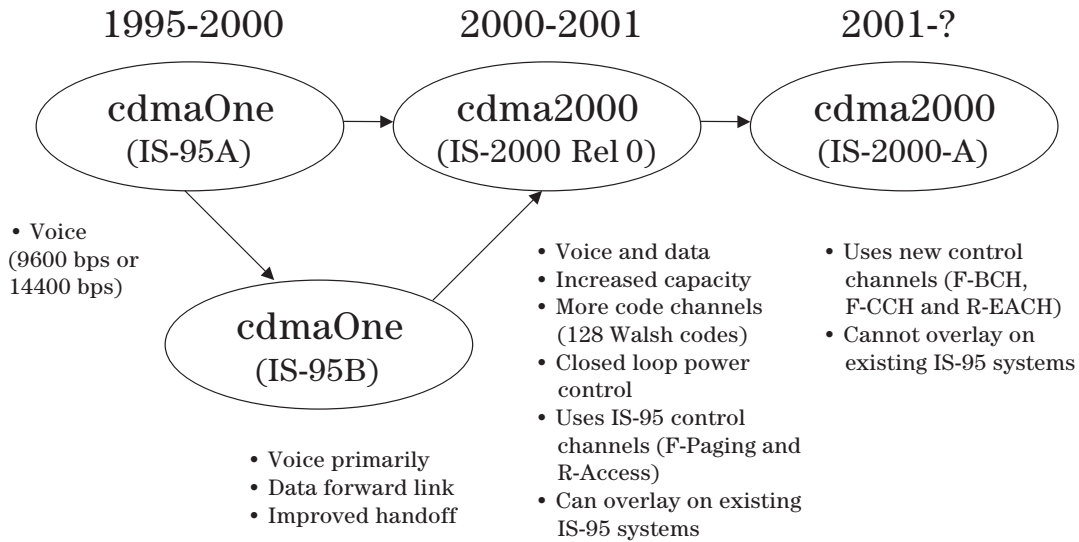

Figure 1. Evolution from cdmaOne to cdma2000

1.1 Spreading rate

Spreading rate (SR) defines the final spread chip rate in terms of 1.2288 Mcps. The two spreading rates are SR1 and SR3.

SR1: A SR1 signal has a chip rate of 1.2288 Mcps and occupies the same bandwidth as cdmaOne signals. The SR1 system doubles the system capacity, therefore, it can be considered an improved cdmaOne system. The main differences from cdmaOne are

- fast power control and quadrature phase shift keying (QPSK) modulation rather than dual binary phase shift keying (BPSK) in the forward link
- pilot signal, to allow coherent demodulation, and hybrid phase shift keying (HPSK) spreading in the reverse link

SR3: An SR3 cdma2000 signal has a rate of 3.6864 Mcps (3 x 1.2288 Mcps) and occupies three times the bandwidth of cdmaOne. Originally, the SR3 system appeared to be viable. Upon further investigation the SR3 cdma2000 system was determined to not be viable and is no longer receiving any commercial attention at this time. Therefore, we will not be covering SR3 in this application note.

1.2 Radio configuration

Radio configuration (RC) defines the physical channel configuration based upon a specific channel data rate. Each RC specifies a set of data rates based on either 9.6 or 14.4 kbps. These are the two existing data rates supported for cdmaOne. Each RC also specifies the spreading rate (either SR1 or SR3) and the physical coding. Currently there are nine radio configurations defined in the cdma2000 system for the forward link and six for the reverse link. Examples are:

- RC1 is the backwards compatible mode of cdmaOne for 9600-bps voice traffic. It includes 9.6, 4.8, 2.4, and 1.2 kbps data rates and operates at SR1. It does not use any of the new cdma2000 coding improvements.
- RC3 is a cdma2000 specific configuration based on 9.6 kbps that also supports 4.8, 2.7, and 1.5 kbps for voice, while supporting data at 19.2, 38.4, 76.8, and 153.6 kbps and operates at SR1.

Each base transceiver station (BTS) or MS must be capable of transmitting using different RCs at the same SR. Refer to [2] for detailed information on the different RCs.

1.3 Forward link air interface

The forward link air interface for a cdma2000 SR1 channel is very similar to that of cdmaOne. In order to preserve compatibility, cdma2000 uses the same structure as cdmaOne for the forward pilot (F-Pilot), forward sync (F-Sync), and forward paging (F-Paging) channels.

In cdma2000, each user is assigned a forward traffic (F-Traffic) channel, which consists of

- zero to one forward fundamental channel (F-FCH)
- zero to seven forward supplemental code channels (F-SCCHs) for RC1 and RC2
- zero to two forward supplemental channels (F-SCHs) for RC3 to RC9
- zero to one forward dedicated control channels (F-DCCHs)

The F-FCHs are used for voice and the F-FCCHs and F-SCHs are used for data. The BTS may also send zero or one F-DCCHs. An F-DCCH is associated with traffic channels (either FCH, SCH, or SCCH) and may carry signaling data and power control data.

One of the main differences between cdmaOne and cdma2000 is that the latter uses true quadrature phase shift keying (QPSK) modulation (as opposed to dual-BPSK) for all traffic channels from RC3 to RC9. As an example, figure 2 shows the forward link structure for an RC4 F-FCH. The coding is identical to cdmaOne up through the long code scrambling of the voice data. The F-FCH is optionally punctured with the reverse link power control data bits. The data is then converted from a serial bit stream into a 2-bit wide parallel data stream to produce true QPSK modulation. This reduces the data rate of each stream by a factor of two. Each branch is spread with a 128 Walsh code to generate a spreading rate of 1.2288 Mcps. In this case, the processing gain is doubled for each channel relative to cdmaOne. Each channel is transmitted at one-half the power used before, but there are now two of them for no apparent gain. The actual processing gain for each channel depends on its data rate and RC.

The outputs of the I and Q Walsh spreaders are then complex multiplied against the same I and Q channel short codes used in cdmaOne. Complex scrambling is used in the forward link instead of regular scrambling because it is a more robust scheme against interference.

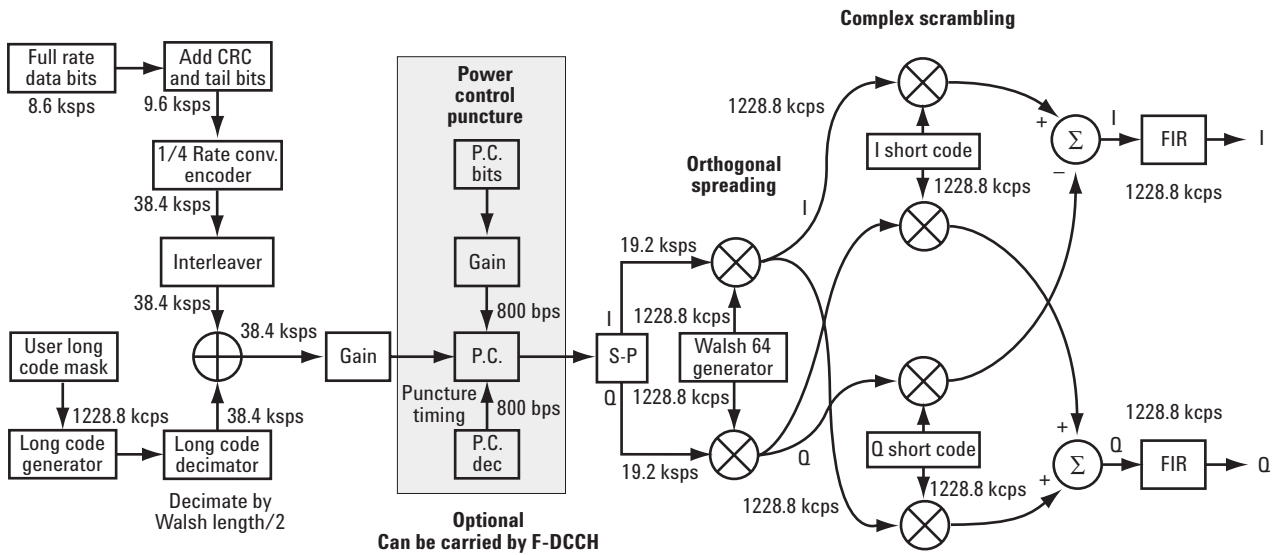

Figure 2. Coding and air interface for a cdma2000 RC4 F-FCH

1.4 Reverse link air interface — HPSK

The cdma2000 reverse link is very different from cdmaOne. The MS can transmit more than one code channel to accommodate the high data rates. The minimum configuration consists of a reverse pilot (R-Pilot) channel to allow the BTS to perform synchronous detection and a reverse fundamental channel (R-FCH) for voice. Additional channels, such as the reverse supplemental channels (R-SCHs) and the reverse dedicated control channel (R-DCCH) can be used to send data or signaling information, respectively.

The different channels are assigned to either the I or Q path. For example, for RC3 to RC6, the R-Pilot is assigned to I and R-FCH is assigned to Q (see figure 3).

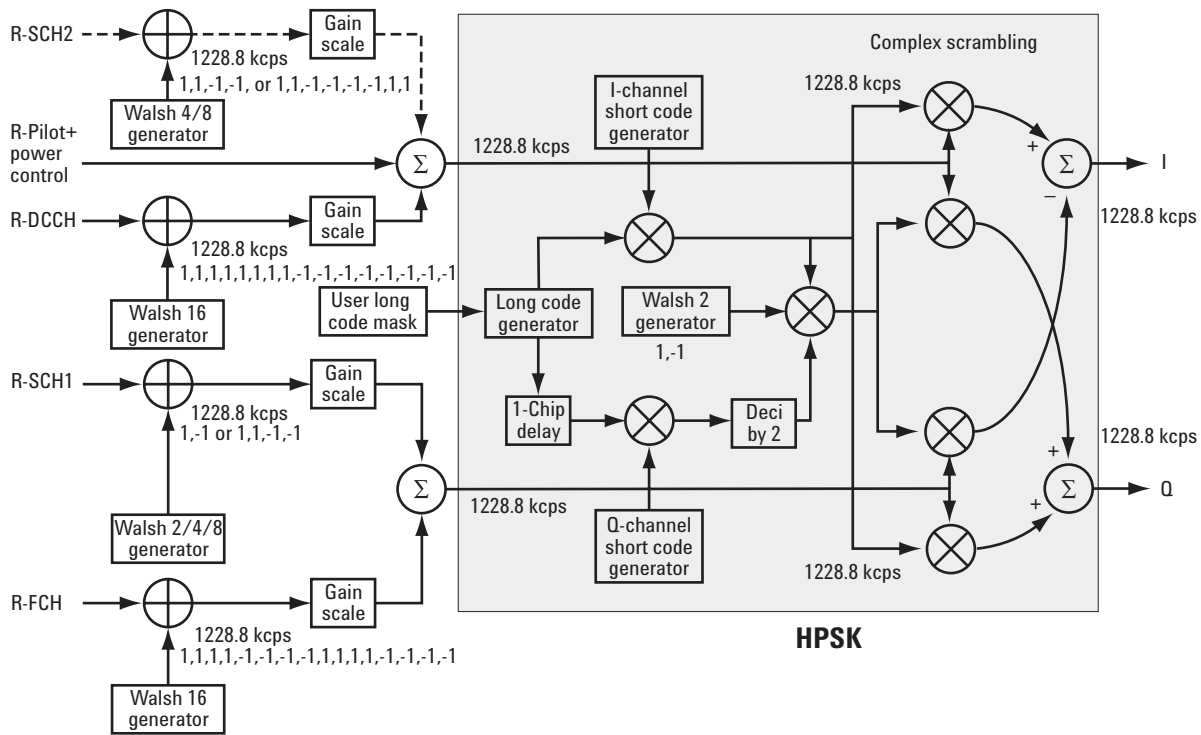

Figure 3. An example of channel summing and HPSK spreading in cdma2000 reverse link (SR1).

Channels can be at different rates and different power levels. Complex scrambling facilitates this by continuously phase rotating the constellation and thus distributing the power evenly between the axes.

Without scrambling, unequal channel powers would result in a rectangular four-quadrature amplitude modulation (QAM) constellation (assuming that only R-Pilot and R-FCH are active). With complex scrambling, the constellation for two channels generally has eight points distributed around a circle, with the angular distribution determined by the relative powers of the two channels. For example, an amplitude difference of 6 dB between the two channels results in the constellation shown in figure 4, which is close to an 8-PSK (8-phase shift keying) constellation (an amplitude difference of 7.65 dB would result in a perfect 8-PSK constellation). If the amplitudes for the two channels are equal, then pairs of constellation points merge to give a QPSK-like constellation.

I/Q measured polar vector

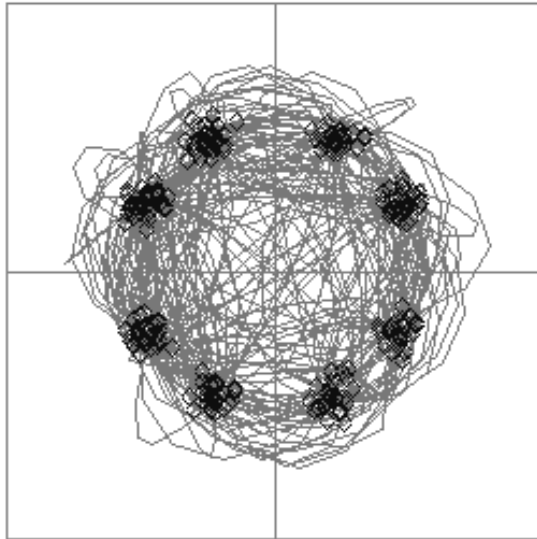

Figure 4. A reverse link cdma2000 SR1 signal with an R-Pilot and an R-FCH. The amplitude of the R-FCH is 6 dB lower than that of the R-Pilot.

Basic complex scrambling applies a phase rotation of 0 , $\pm\pi/2$, or π radians to each chip. HPSK takes this idea a stage further and defines the complex scrambling so that for every second chip, the phase rotation is restricted to $\pm\pi/2$. This constraint on the phase transitions entering the baseband pulse shaping filter reduces the peak-to-average ratio of the signal (about 1 to 1.5 dB) compared to regular complex scrambling (or regular QPSK). The HPSK technique continues to be advantageous even when the signal has more than two channels. For more information on HPSK see [3].

1.5 Forward link power control

A key improvement in cdma2000 is forward link power control. The MS sends power control data back to the BTS by time multiplexing it with the R-Pilot channel. Like the existing reverse link closed loop power control of cdmaOne, the cdma2000 forward link closed loop power control sends 800 power control bits each second. These bits indicate whether the BTS should raise or lower its power in 1 dB, 0.5 dB, or 0.25 dB. The finer steps allow tighter power control for low mobility or stationary phones. Tighter control (less power ripple) lowers the average power and thus raises the capacity of the system.

1.6 Differences between cdma2000 and W-CDMA

The Third-Generation Partnership Project (3GPP) W-CDMA is the other main wideband CDMA technology competing for the 3G cellular market. There has been much discussion about the need to harmonize W-CDMA and cdma2000 in an attempt to facilitate global use of 3G phones. However, even though both systems are based on a similar CDMA technology, they are significantly different. The main differences are

- the spreading rate (3.84 Mcps for W-CDMA versus 1.2288 Mcps for cdma2000 SR1)
- the synchronization and BTS identification methodology (W-CDMA does not use global positioning system (GPS))

For information on W-CDMA user equipment (UE)¹ design and test issues, please refer to [4].

1. The W-CDMA specifications use the term UE to refer to mobile phones, wireless computing devices, or other devices that provide wireless access to the W-CDMA system.

2 Design and measurement issues

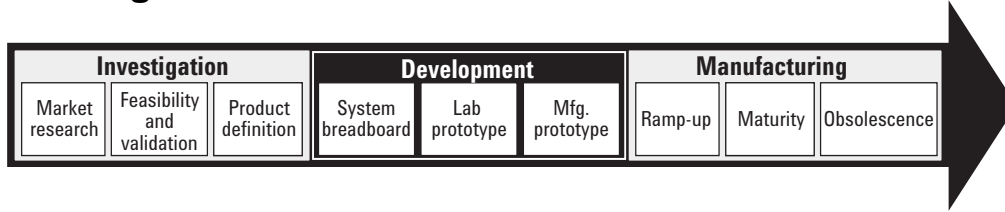

Figure 5. R&D and manufacturing phases of an MS

Figure 5 shows a generic diagram for the R&D and manufacturing phases of a MS. This chapter focuses on the development phase of the MS, highlighted in black. However, it contains general information useful to engineers involved in any area of the MS life cycle.

This chapter describes design and measurement issues that you may encounter when designing and testing a cdma2000 MS, in contrast to cdmaOne. Although the exact cdma2000 measurement specifications are not finalized, in general we can assume that, when possible, the basic measurement methodology will be similar to cdmaOne. Therefore, in this section cdmaOne measurements are used as a reference. For information on cdmaOne measurements refer to [1].

Refer to the appendix for a list of Agilent solutions available for MS design and test.

2.1 Maximizing battery life

Long battery life is a key competitive advantage for the mobile phone. cdmaOne uses offset quadrature phase shift keying (OQPSK) as the modulation format for the reverse link. OQPSK minimizes the peak-to-average power ratio by avoiding signal envelope transitions through zero. Peak-to-average power ratio is the ratio of the peak envelope power to the average envelope power of a signal. If the peak-to-average power ratio is small, the headroom required in the amplifier to prevent compression of the signal and interference with the adjacent frequency channels is small. Thus, the amplifier can operate more efficiently.

In cdma2000 the handset can transmit multiple channels to accommodate the high data rates. Modulation schemes such as OQPSK or Gaussian minimum shift keying (GMSK) do not prevent zero-crossings for multiple channels and are no longer suitable. Instead, QPSK is used in combination with HPSK to minimize the peak-to-average power ratio. (For more information on HPSK see [3].) With this technique, the peak-to-average power ratio for the basic configuration (an R-Pilot channel and an R-FCH) is equal to or larger than 4 dB during 0.1 percent of the time (see figure 6). Even though HPSK reduces the peak-to-average power ratio, it still increases as code channels are activated for higher data rates because the amplitude vectors of each code channel add to each other.

A severe case occurs if two supplemental channels at high data rates are required. In this case, the benefits of HPSK may be lost (see section 2.2.3). This is rarely expected to happen since the forward link will carry most of the high data rate traffic.

The amplifier must be capable of handling the different peak-to-average power ratios the signal exhibits for the different channel configurations, while maintaining a good adjacent channel power (ACP) performance.

From the measurement perspective, the statistics of the signal may impact the result of the measurement, particularly in the case of adjacent channel power ratio (ACPR). Therefore, it is important to choose the signal's channel configuration carefully. You need to cover the real-life worst cases, such as those with the most stressful signal configurations or highest peak-to-average power ratios. To do that, you need a way to define the statistics of cdma2000 reverse link signals. The complementary cumulative distribution function (CCDF) does that for you.

2.1.1 CCDF

The CCDF fully characterizes the power statistics of the signal [5]. It provides the distribution of particular peak-to-average power ratios versus probability.

Figure 6 compares the CCDF curves for a signal with R-Pilot and R-FCH, and a signal with R-Pilot, R-FCH, R-SCH1 at 153.6 kbps, and R-SCH2 at 153.6 kbps. For a probability of 0.1 percent, the signal with two supplemental channels has a peak-to-average power ratio 2 dB higher than the signal with only an R-Pilot and an R-FCH. As mentioned earlier, adding code channels, in general, increases the peak-to-average power ratio of the signal [5].

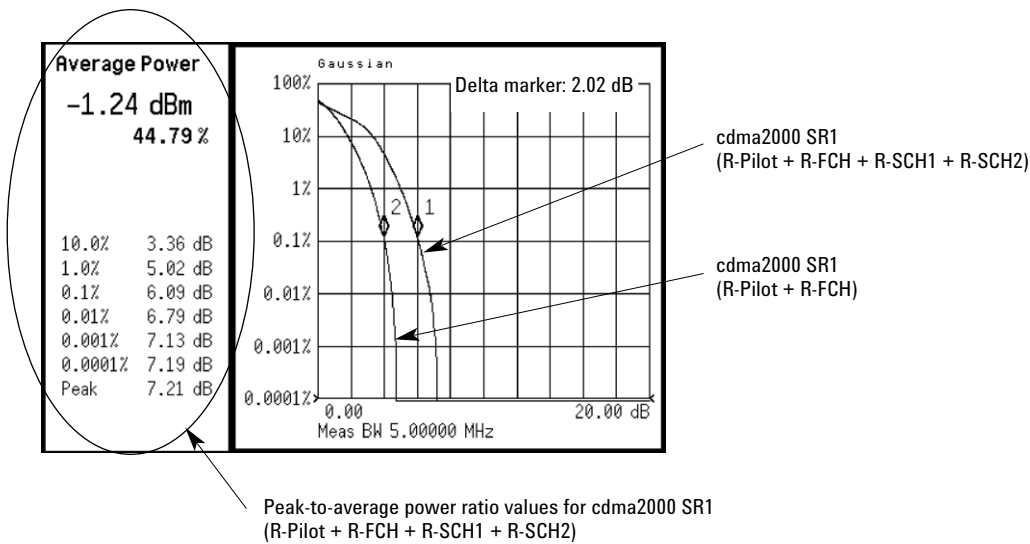

Figure 6. CCDF curves for two cdma2000 SR1 reverse link signals with different channel configurations

So, how do the statistics of cdmaOne compare to the statistics of cdma2000? Figure 7 shows the CCDF for a cdmaOne reverse link signal and the CCDF for a cdma2000 signal with an R-Pilot and an R-FCH. At 0.1 percent the peak-to-average power ratio of the cdma2000 SR1 signal is 0.5 dB lower than the cdmaOne signal.

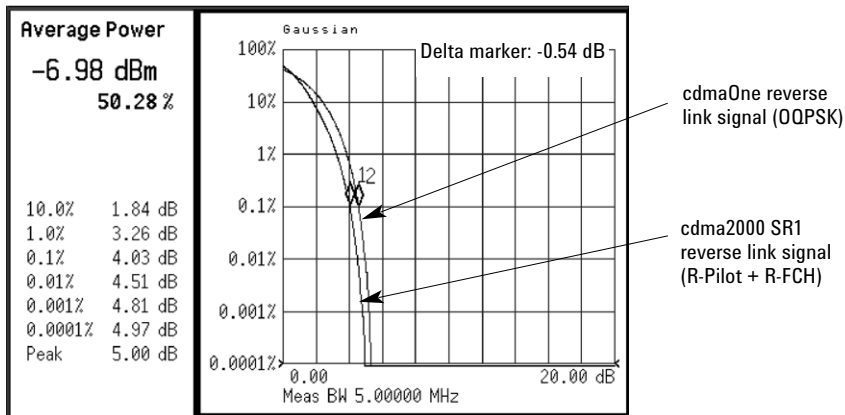

Figure 7. CCDF comparison between cdmaOne and cdma2000 reverse link signals

CCDF curves can help you in several situations:

- Determining the headroom required when designing a component. You can do this by correlating the CCDF curve of the signal with the amplifier gain plots [5].
- Confirming the power statistics of a given signal or stimulus. CCDF curves allow you to verify if the stimulus signal provided by another design team is adequate. For example, RF designers can use CCDF curves to verify that the signal provided by the digital signal processing (DSP) section is realistic.
- Confirming the component design is adequate, or troubleshooting your subsystem or system design. You can make CCDF measurements at several points of the system design. For example, if the ACPR of the transmitter is too high, you can make CCDF measurements at the input and output of the power amplifier. If the amplifier design is correct, the curves will coincide. If the amplifier compresses the signal, the peak-to-average power ratio of the signal will be lower at the output of the amplifier.

2.1.2 ACPR

The ACPR is usually defined as the ratio of the average power in the adjacent frequency channel (or at a specified frequency offset) to the average power in the transmitted frequency channel. The ACPR measurement is not part of the IS-95 standard, however, individual network equipment manufacturers typically specify ACPR as a figure of merit for component testing [1].

As mentioned earlier, when testing ACPR it is important to take into account the power statistics of the signal. A signal with a higher peak-to-average ratio may cause more interference in the adjacent channel. Thus, ACPR measurements can provide different results depending on the signal configuration. The safest approach is to select at least one high-stress cdma2000 stimulus signal and test with various combinations of channels.

The appropriate ACPR measurement parameters for cdma2000 depend on the SR. For SR1, you can use the cdmaOne parameters since cdmaOne and cdma2000 both use the same chip rate and filtering. Figure 8 shows the ACPR measurement for a cdma2000 SR1 reverse link signal.

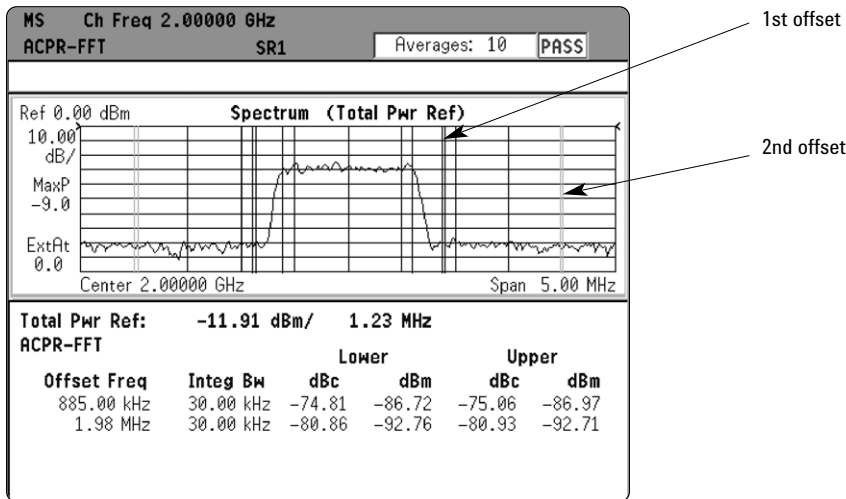

Figure 8. ACPR measurement for a cdma2000 SR1 reverse link signal

2.2 Measuring modulation accuracy

Measuring modulation accuracy for cdma2000 MS is more complex than for cdmaOne MS. Since the cdma2000 MS can transmit several channels, think of it as a miniature BTS. It requires the same kind of tests (code domain analysis, etc.) you would perform on any CDMA BTS.

There are many measurements available to analyze the modulation accuracy of a cdma2000 MS transmitter: rho (pilot-only), QPSK error vector magnitude (EVM), composite rho and EVM, code domain power, symbol EVM per code channel, etc. Apart from their basic algorithm, these measurements differ mainly on three aspects:

- whether you can use them to analyze a signal with a single (QPSK EVM) or multiple (composite rho, code domain power, symbol EVM) code channels
- if you can use them to analyze multi-channel signals, whether they provide information about each channel (code domain power, symbol EVM) or about the overall signal with no differentiation between channels (composite rho)
- how (what degree of demodulation) and at what level (chip, symbol) the reference is computed

The best measurement to use depends on the design stage and the test purpose. In general, these measurements can complement each other by providing additional pieces of information. The following sections intend to clarify what information these measurements provide and when to apply them.

2.2.1 QPSK EVM

In digital communication systems, signal impairment can be objectively assessed by looking at the constellation and taking the displacement of each measured dot from the reference position as an error phasor (or vector), as shown in figure 9.

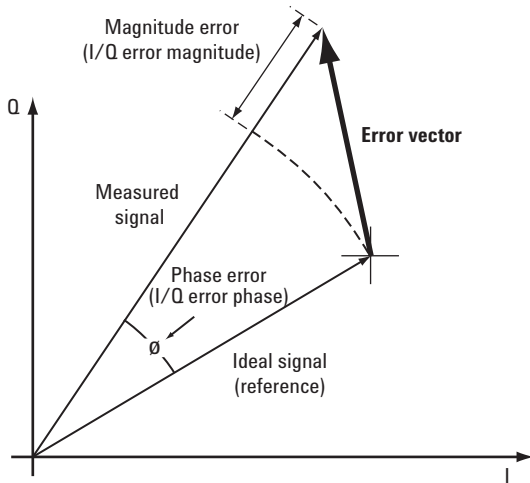

Figure 9. Error vector and related parameters

The reference position is determined from a reference signal that is synthesized by demodulating the received signal to symbols and then remodulating these symbols "perfectly". For example, figure 10 shows how the ideal reference is calculated for a QPSK signal.

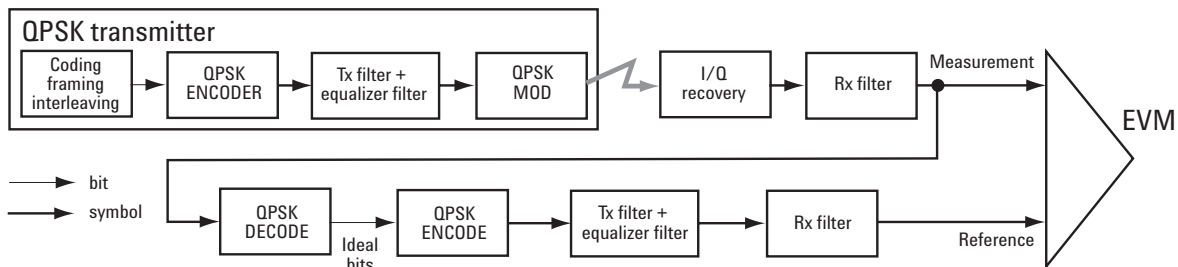

Figure 10. Process to calculate EVM for a QPSK signal

The root mean square (RMS) of the error vectors is computed and expressed as a percentage of the overall signal magnitude. This is the error vector magnitude (EVM). EVM is a common modulation quality metric widely used in digital communication systems. (See [6] for more information on how to use EVM as a troubleshooting tool.)

For a regular QAM or a phase shift keying (PSK) signal the ideal symbol points always map onto a few specific locations in the I/Q plane. The cdma2000 reverse link signal can consist of multiple channels that are I/Q multiplexed. This means the one-bit symbols for each channel are BPSK encoded¹ for either the I or the Q path. Several channels can be added to the I and/or the Q paths. The resulting I and Q signals are then spread and HPSK scrambled (see figure 3). The complex-valued chip sequence is then filtered and the result is applied to the QPSK modulator². The cdma2000 MS transmitter in figure 11 illustrates this process.

1. BPSK encoding, in this case, refers to the process of mapping the one-bit symbols for a channel onto the I (or the Q) path in serial. This means the symbols for a channel are directly converted into I (or Q) levels. For example, 1001 would be converted to 1 -1 -1 1.

2. QPSK modulation, in this case, refers to the upconversion process (the process of modulating the radio frequency (RF) carrier with the I/Q baseband signal).

The resulting constellation depends on the physical channel configuration. The constellation typically does not look like QPSK or any other known constellation. Except for some very specific channel configurations, for example, a signal with a single R-Pilot (or a single R-FCH) does map onto a QPSK constellation. A signal with both a R-Pilot and a R-FCH at the same amplitude level maps onto a 45°-rotated QPSK constellation [3]. Since the receiver does not care about the absolute phase rotation, it effectively sees a QPSK constellation.

You can use a regular QPSK EVM measurement to evaluate the modulation quality of the transmitter for a single R-Pilot, a single R-FCH, or a signal with both at the same amplitude level. More complex signals cannot be analyzed with this measurement.

The signal analyzer may use either of the following methodologies to make a QPSK EVM measurement:

1. **Measure QPSK EVM on the received signal.** Filter the recovered I/Q signal with the equalizer and complementary receiver filters and compare it with a reference signal calculated by filtering the demodulated signal with the transmitter, equalizer, and receiver filters (figure 11a).
2. **Measure QPSK EVM on the transmitted signal.** Compare the I/Q recovered signal directly with a reference signal calculated by filtering the ideal chips with the transmitter filter (figure 11b).

Both methods yield similar EVM results and you can use either of them to make valid modulation quality measurements of the MS transmitter; however, the resulting constellation looks different. The first method results in four discrete constellation points. The second method results in a fuzzy constellation, as shown in Figure 12a. The constellations for both methods are correct. The reason for the difference is that, for the first method, the constellation displays what the receiver sees after filtering, while the second method displays the constellation of the transmitted signal before applying any receiver filtering.

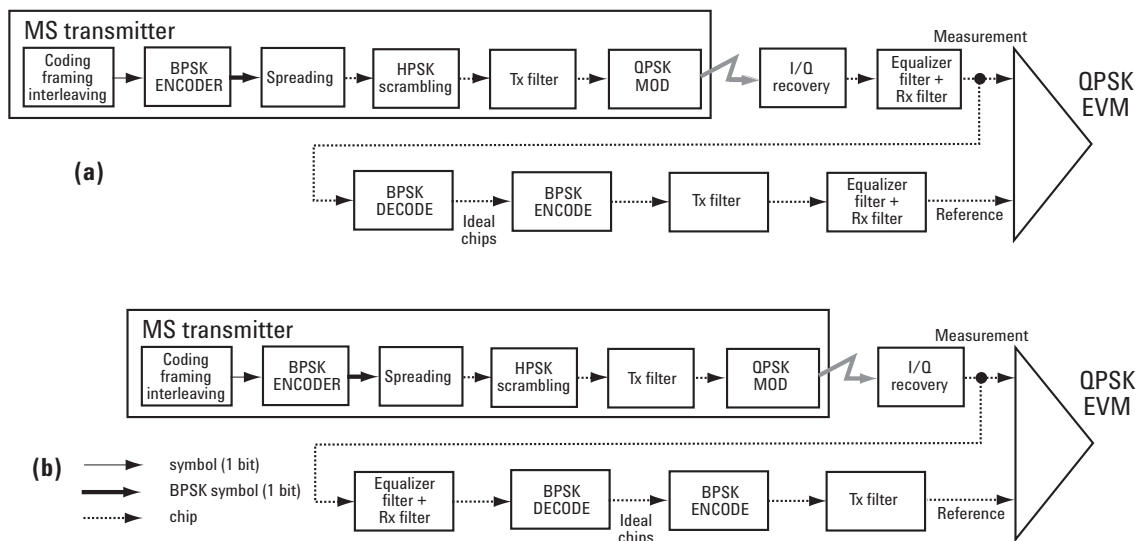

Figure 11. Process to calculate QPSK EVM for a cdma2000 reverse link signal

In any case, QPSK EVM does not descramble and despread the signal into symbols and back into chips to calculate the appropriate reference. Therefore, it can detect baseband filtering, modulation, and the intermediate frequency (IF) and RF impairments, but does not detect spreading or scrambling errors. In addition, QPSK EVM cannot evaluate the modulation quality of a multi-channel signal.

If it is impossible to despread or descramble the signal, the QPSK EVM measurement may be the only choice. In this sense, the QPSK EVM measurement can be useful to RF designers or system integrators to evaluate the modulation quality of the analog section of the transmitter when the spreading or HPSK scrambling algorithms are not available or do not work properly. For example, figure 12 shows a QPSK EVM measurement for a single R-Pilot for a transmitter with and without an I/Q gain problem.

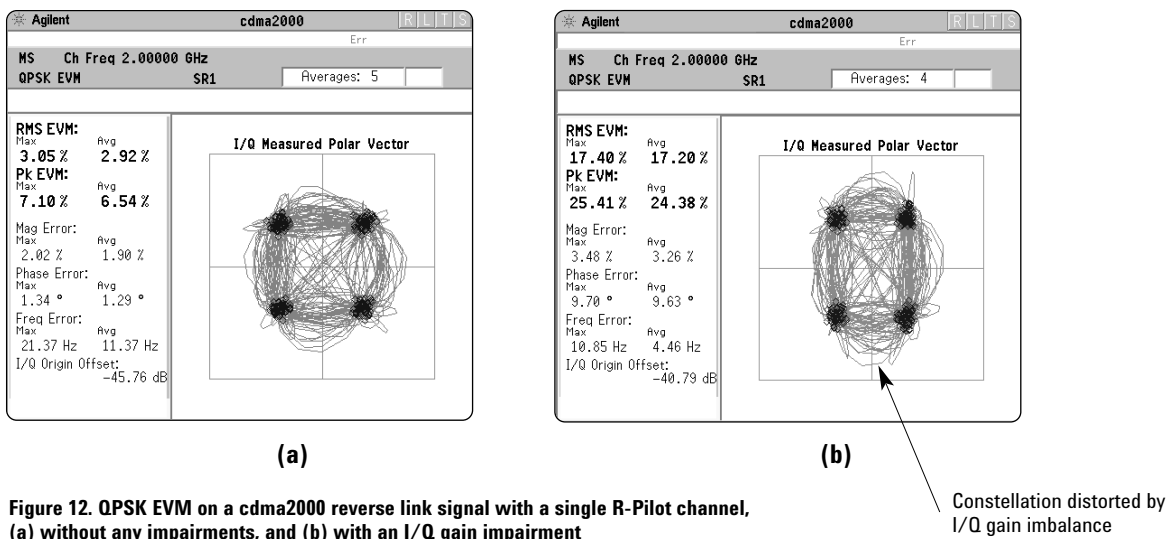

Figure 12. QPSK EVM on a cdma2000 reverse link signal with a single R-Pilot channel, (a) without any impairments, and (b) with an I/Q gain impairment

Constellation distorted by I/Q gain imbalance

You can use the vector diagram, error vector versus time or frequency, magnitude error and phase error versus time to troubleshoot the impairment. For example, most I/Q impairments (such as the I/Q gain error in figure 12b) can be easily recognized by looking at the vector diagram, while in-channel spurious can be detected by analyzing the error vector spectrum [6].

2.2.2 Composite rho

In cdma2000, as in cdmaOne, the specified measurement for modulation accuracy is rho. Rho is the ratio of the correlated power to the total power. The correlated power is computed by removing frequency, phase, and time offsets and performing a cross-correlation between the corrected signal and an ideal reference.

In cdmaOne, the rho measurement is performed on the reverse link signal that consists of a single channel. In cdma2000, the rho measurement is defined for a signal with a R-Pilot only.

In practice, you can perform a rho measurement on any cdma2000 reverse link signal, regardless of the channel configuration. For this reason, the measurement is usually called composite rho. Composite rho allows you to verify the overall modulation accuracy for a transmitter, regardless of the channel configuration, as long as a R-Pilot is present. The measurement algorithm involves descrambling and despreding the measured signal to calculate the reference signal, as shown in figure 13.

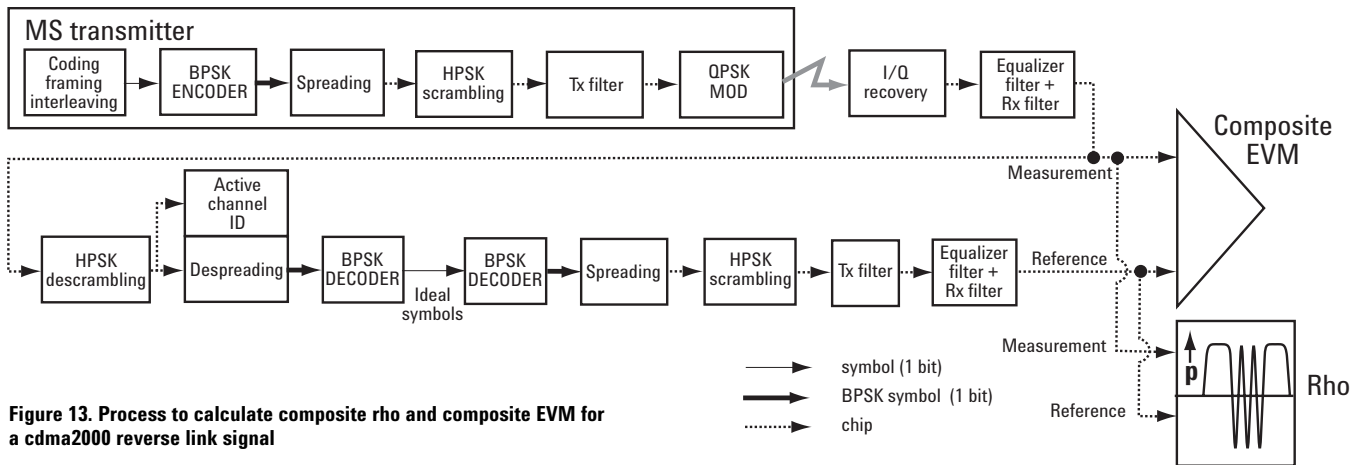

Figure 13. Process to calculate composite rho and composite EVM for a cdma2000 reverse link signal

A composite rho measurement accounts for all spreading and scrambling problems in the active channels and for all baseband, IF, and RF impairments in the transmitter chain. However, unless combined with a constellation diagram and other modulation accuracy measurements, rho (or composite rho) does not help you identify the cause of the error. Figures 14a and 14b show composite rho combined with one of these measurements (composite EVM) and the constellation for a signal with an R-Pilot and an R-FCH and a signal with an R-Pilot, R-FCH, and one R-SCH, respectively.

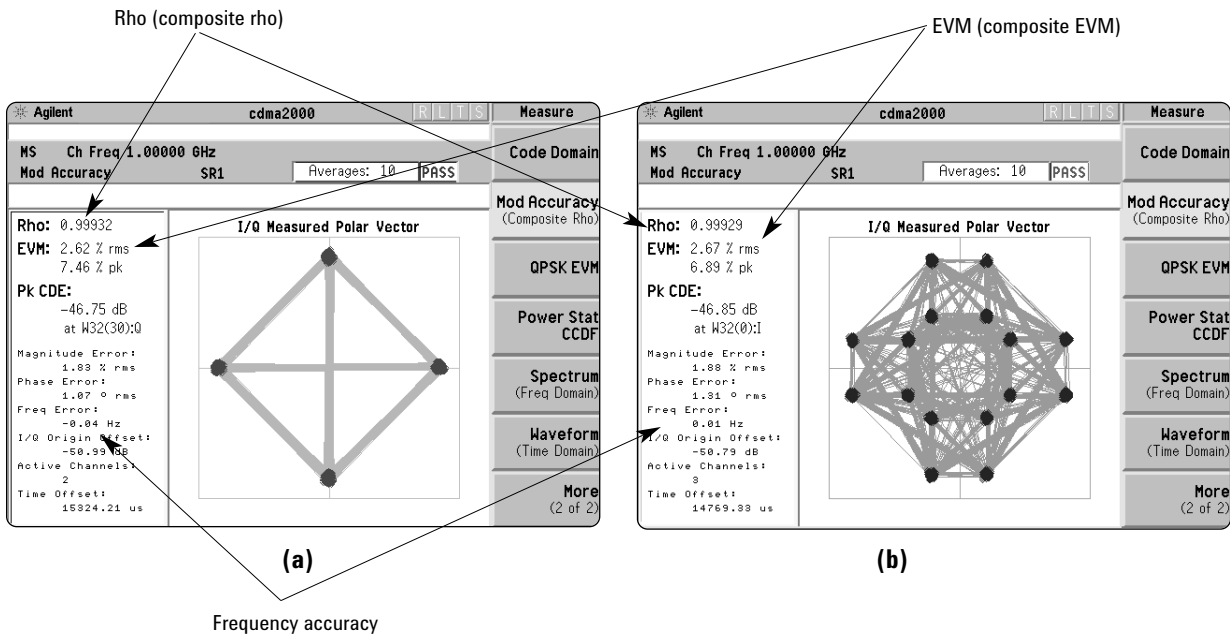

Figure 14. Composite rho measurement for (a) a cdma2000 SR1 reverse link signal with an R-Pilot and an R-FCH, and (b) a cdma2000 SR1 signal with an R-Pilot, an R-FCH and one R-SCH (the R-FCH is 3 dB lower than the other two channels)

Like QPSK EVM, composite EVM calculates the error vector difference between the measured and the ideal signal. The difference is that composite EVM uses the same reference as composite rho – that is, it descrambles and despreads the measured signal to calculate the reference (figure 13).

By performing a composite rho or composite EVM test, you also obtain a measure of the frequency accuracy (see figure 14), required in cdmaOne and in the IS-2000 standard.

Here are some situations in which you should use composite rho (and composite error vector measurements) instead of a QPSK EVM measurement:

- **To evaluate the quality of the transmitter for a multi-channel signal.**

This is particularly important for RF designers who need to test the RF section (or components) of the transmitter using realistic signals with correct statistics. As mentioned earlier, in general, the peak-to-average power ratio of the signal increases as the number of channels increases. By measuring modulation quality on a multi-channel signal, you can analyze the performance of the RF design for cdma2000 reverse link signals with different levels of stress (different CCDFs). Evaluating the modulation quality of multi-channel signals is also important for the baseband designers to analyze the performance of multi-board baseband designs. For example, a small timing error in the clock synchronization between channels on different boards can be detected as a decrease in modulation quality.

- **To detect spreading or scrambling errors.** Depending on the degree of the error, the analyzer may show an intermittent unlock condition or may not be able to lock at all when trying to perform a composite rho measurement. These conditions are mainly of interest to system integrators to determine errors in the spreading and scrambling. Should this problem occur, you can use the QPSK EVM measurement to confirm the rest of the transmitter is working as expected. If the scrambling or spreading error does not cause an unlock measurement condition, you can use the error vector versus time display to find the problematic chip.

- **To detect certain problems between the baseband and RF sections.**

Again, these cases are mainly of interest to system integrators. You may be able to use the QPSK EVM measurement to detect some of these problems. For example, local oscillator (LO) instability caused by interference from digital signals can be detected with QPSK EVM. However, the QPSK EVM measurement will not detect problems that require synchronization with the signal. For example, I/Q swapped errors will look perfectly normal if a QPSK EVM measurement is used. On the other hand, it will cause an unlock condition when performing a composite rho measurement.

- **To analyze errors that cause high interference in the signal.** If the interference is too high, the QPSK EVM measurement may not be able to recover the true ideal reference. In this case, the QPSK EVM and its related displays are not accurate. Since the composite rho measurement descrambles and despreads the signal, it takes advantage of the signal's processing gain. This allows the analyzer to recover the true reference even when the signal is well beyond the interference level that will cause multiple chip errors. Therefore, composite rho and composite EVM are true indicators of modulation fidelity even when the signal under test is buried by interference. In this sense, these measurements may be particularly useful in hostile field environments with high levels of interference. System integrators can use the composite EVM measurement to analyze the quality of the

MS at the system level. By applying external interference to the signal transmitted by the MS you can evaluate how bad the EVM can get before the signal analyzer cannot recover the signal. This allows you to verify what the minimum modulation accuracy for the MS transmitter should be in order for the BTS to demodulate the signal in realistic field environments. The processing gain benefits of composite rho (or EVM) can also be useful to RF designers and system integrators for occasional bad cases of interference. For example, figure 15a shows the phase error versus time for a QPSK EVM measurement and figure 15b shows the phase error versus time for a composite rho (or EVM) measurement for a pilot-only signal with a very high LO instability. In this case, the analyzer can demodulate the signal and calculate the reference accurately. The phase error display in figure 15b will allow you to analyze the interference.

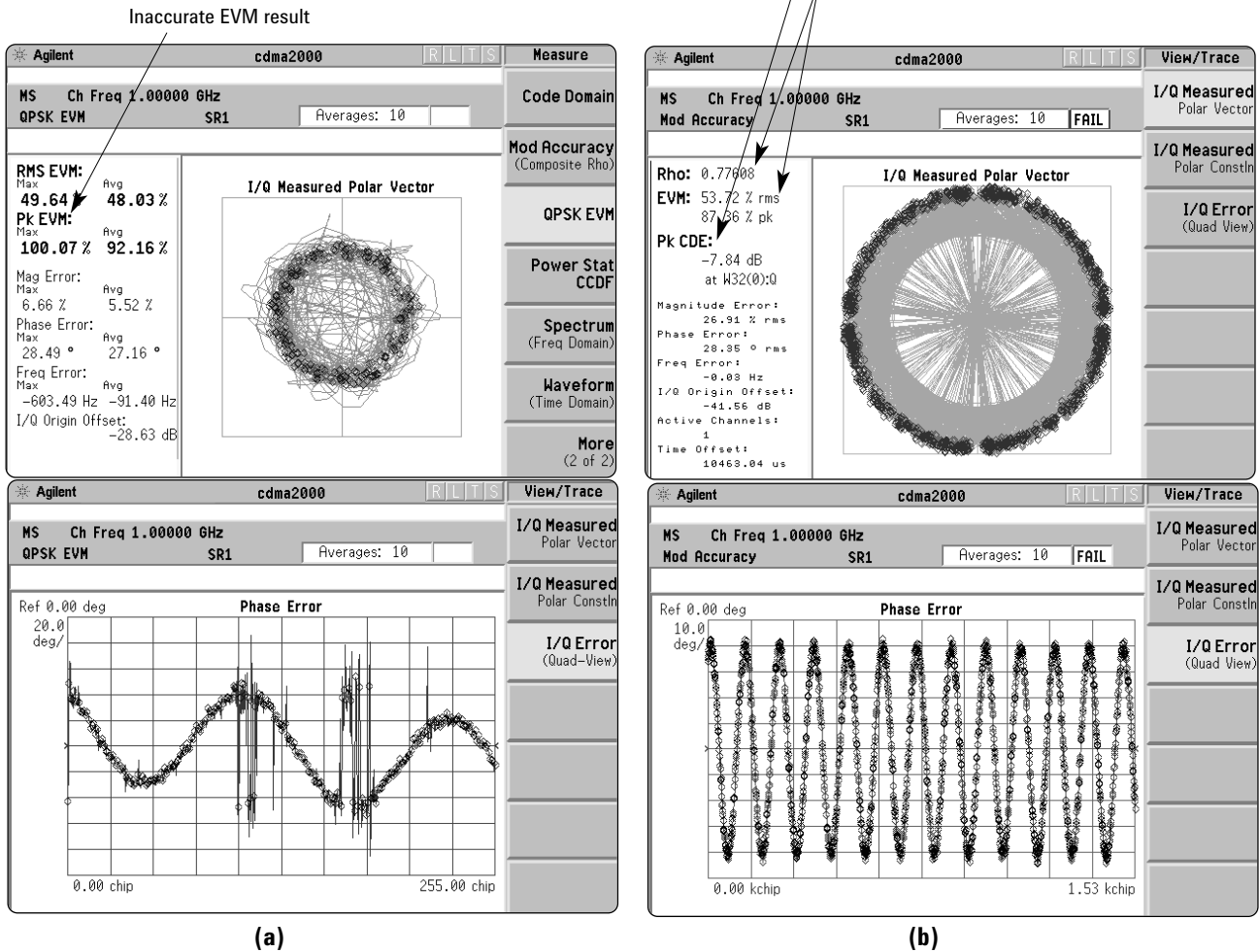

Figure 15. cdma2000 R-Pilot signal with very high LO instability. (a) Vector diagram and phase error versus time for QPSK EVM. (b) Vector diagram and phase error versus time for composite EVM (provided with composite rho measurement).

Composite rho is useful throughout the development, performance verification, manufacturing, and installation phases of the MS life cycle as a figure of merit for the transmitter as a whole. However, we are also interested in the code-by-code composition of the composite signal. The primary means of investigating this is to look at the distribution of power in the code domain.

2.2.3 Code domain power

Code domain power is an analysis of the distribution of signal power across the set of code channels, normalized to the total signal power. To analyze the composite waveform each code channel is decoded using a code-correlation algorithm. This algorithm determines the correlation coefficient factor for each code. Once the channels are decoded, the power in each code channel is determined.

In cdma2000, the measurement is complicated by the fact that the length of the Walsh codes varies to accommodate the different data rates and SRs of the different RCs. In general, as the data rate increases the symbol period is shorter. For a specific SR, the final chip rate is constant. Therefore, fewer Walsh code chips are accommodated within the symbol period – the Walsh code length is shorter.

One effect of using variable length Walsh codes for spreading is that a shorter code precludes using all longer codes derived from it. Figure 16 illustrates this concept. If a high data rate channel using a 4-bit Walsh code such as 1, 1, -1, -1 is transmitted, all lower data rate channels using longer Walsh codes that start with 1, 1, -1, -1 have to be inactive to avoid conflicts in the correlation process at the receiver.

Walsh 4		Walsh 8		Walsh 16	
0	1 1 1 1	0	1 1 1 1 1 1 1 1	0	1 1 1 1 1 1 1 1 1 1 1 1 1 1 1 1
1	1 -1 1 -1	1	1 -1 1 -1 1 -1 1 -1	1	1 -1 1 -1 1 -1 1 -1 1 -1 1 -1 1 -1 1 -1
2	1 1 -1 -1	2	1 1 -1 -1 1 1 -1 -1	2	1 1 -1 -1 1 1 -1 -1 1 1 -1 -1 1 1 -1 -1
3	1 -1 -1 1	3	1 -1 -1 1 1 -1 -1 1	3	1 -1 -1 1 1 -1 -1 1 1 -1 -1 1 1 -1 -1
		4	1 1 1 1 -1 -1 -1 -1	4	1 1 1 1 -1 -1 -1 -1 1 1 1 1 -1 -1 -1 -1
		5	1 -1 1 -1 -1 -1 1 -1	5	1 -1 1 -1 -1 -1 1 -1 1 1 -1 1 -1 -1 1 -1
		6	1 1 -1 -1 -1 -1 1 1	6	1 1 -1 -1 -1 -1 1 1 1 1 -1 -1 -1 -1 1 1
		7	1 -1 -1 1 -1 -1 1 1	7	1 -1 -1 1 -1 -1 1 1 -1 -1 -1 -1 1 -1 1 -1
				8	1 1 1 1 1 1 1 1 -1 -1 -1 -1 -1 -1 -1 -1
				9	1 -1 1 -1 1 -1 1 -1 -1 -1 -1 -1 1 -1 1 -1
				10	1 1 -1 -1 1 1 -1 -1 -1 -1 1 1 -1 -1 1 1
				11	1 -1 -1 1 1 -1 -1 1 -1 1 1 -1 -1 1 1 -1
				12	1 1 1 1 -1 -1 -1 -1 -1 -1 -1 -1 1 1 1 1
				13	1 -1 1 -1 -1 -1 1 -1 1 -1 1 -1 1 1 -1 -1
				14	1 1 -1 -1 -1 -1 1 1 -1 -1 1 1 1 1 -1 -1
				15	1 -1 -1 1 -1 1 1 -1 -1 1 1 -1 1 -1 -1 1

Figure 16. Hadamard generation of Walsh codes and the effects of using variable length Walsh codes for spreading

Individual Walsh codes (or functions) are identified by W_n^N , where N is the length of the code and n is the row in the N x N Hadamard matrix. For example, W_2^4 represents code 2 of the 4 x 4 Hadamard matrix (4-bit Walsh code).

Therefore, W_2^4 precludes using:

- W_2^8 and W_6^8 ;
- W_2^{16} , W_6^{16} , W_{10}^{16} , W_{14}^{16} ;
- W_2^{32} , W_6^{32} , W_{10}^{32} , W_{14}^{32} , W_{18}^{32} , W_{22}^{32} , W_{26}^{32} , W_{30}^{32} (not shown in figure 16); etc.

Another way to look at the same signal is by reordering the code channels so related code channels are adjacent to each other. The so-called bit-reverse generation of Walsh codes provides us with this desired code number assignment. This is the code generation method used in W-CDMA [4]. The codes

derived from this method are called orthogonal variable spreading factor (OVSF) codes, as opposed to Walsh codes, in W-CDMA. OVSF codes and Walsh codes are the same, only their code number assignment is different. The generation method is called “bit-reverse” because the code number in binary form is reversed (MSB is LSB, etc.) relative to the Hadamard method. For example, code channel 3 (binary: 011) in the Hadamard Walsh 8 matrix corresponds to code channel 6 (binary: 110) in the reverse-bit Walsh 8 matrix, as seen in figure 17.

Hadamard (Walsh codes)				Bit-reverse (OVSF codes)			
Actual code (Walsh 8)		Code number		Actual code (Walsh 8)		Code number	
		In decimal	In binary			In decimal	In binary
1 1 1 1	1 1 1 1	0	000	1 1 1 1	1 1 1 1	0	000
1 0 1 0	1 0 1 0	1	001	1 0 1 0	0 0 0 0	1	001
1 1 0 0	1 1 0 0	2	010	1 1 0 0	1 1 0 0	2	010
1 0 0 1	1 0 0 1	3	011	1 0 0 0	0 0 1 1	3	011
1 1 1 1	0 0 0 0	4	100	1 0 1 0	0 0 0 0	4	100
1 0 1 0	0 1 0 1	5	101	1 0 1 0	0 1 0 1	5	101
1 1 0 0	0 0 1 1	6	110	1 0 0 1	1 0 0 1	6	110
1 0 0 1	0 1 1 0	7	111	1 0 0 1	0 1 1 0	7	111

Figure 17. Hadamard versus bit-reverse

For the reverse link, as seen earlier, the physical channels are I/Q multiplexed. HPSK is applied to limit the peak-to-average power ratio. However, HPSK limits the choice of Walsh codes. In order to benefit from this function, only even-numbered Walsh codes, which consist of pairs of identical consecutive chips, can be used. For example, $W_2^4 = (1,1,-1,-1)$ would meet this condition, but $W_1^4 = (1,-1,1,-1)$ would not [3].

To maximize the benefits of HPSK, the Walsh codes for the different channels are defined as follows:

- The R-Pilot is always spread by code $W_0^{32} = (1,1)$.
- The R-FCH is always spread by code $W_4^{16} = (1,1,1,1,-1,-1,-1,-1,1,1,1,1,-1,-1,-1,-1)$.
- The R-DCCH is always spread by code $W_8^{16} = (1,1,1,1,1,1,1,1,-1,-1,-1,-1,-1,-1,-1,-1)$.
- When only one R-SCH is to be transmitted, R-SCH1 is spread by code $W_2^4 = (1,1,-1,-1)$. Only for the highest data rates should $W_1^2 = (1,-1)$ be used. This Walsh code defeats the benefits of HPSK, so it should be avoided.
- When two R-SCHs are used, the recommended configuration is to have SCH1 using $W_2^4 = (1,1,-1,-1)$ and SCH2 using $W_6^8 = (1,1,-1,-1,-1,-1,1,1)$. These two codes are not orthogonal to each other. This is not a problem because, as seen in figure 3, the two channels are I/Q multiplexed (one is transmitted in I and the other one in Q). This makes them orthogonal regardless of the spreading code used. For high data rate cases, both SCHs can use shorter codes.

Figure 18 shows how the selected codes for the different channels map onto the bit-reverse code tree. The dark grey codes are the selected codes. The light grey codes are non-orthogonal to the selected codes.

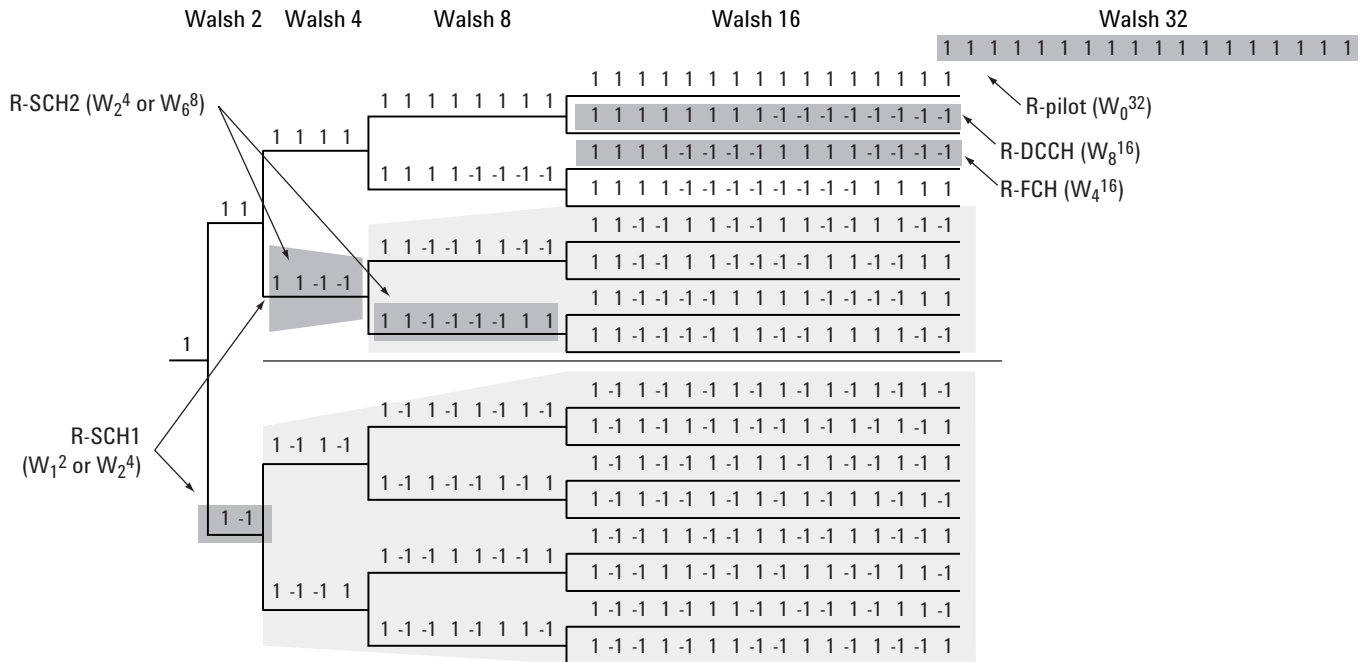
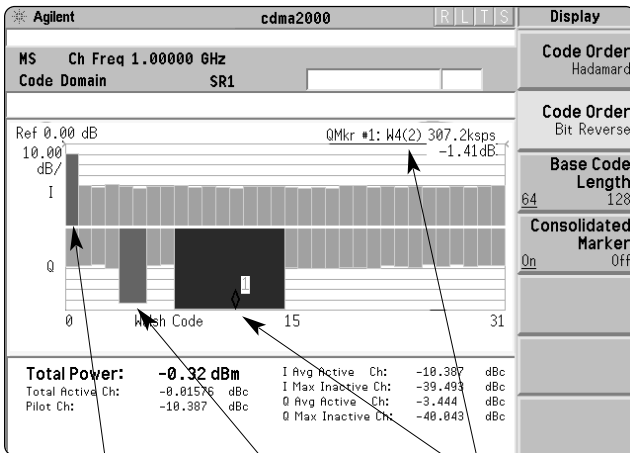

Figure 18. Mapping of reverse link Walsh codes onto the bit-reverse Walsh code tree

For the worst cases (highest data rates), the HPSK requirements will not be fulfilled. It is expected that this will only occur for a very small percentage of cases.

Defining the Walsh codes avoids code-usage conflicts. By limiting the choice of code channel configurations, the power statistics (CCDF) for the signals are also better determined.

In terms of code capacity, channels with higher data rates (shorter code lengths) occupy more code space. For example, W_1^2 occupies two times more code space as W_2^4 , and eight times more code space than W_4^{16} . In the code domain power display, wider bars represent shorter code (higher data rate) channels. Figure 19 shows the code domain power display, in bit-reverse mode, for a signal with an R-Pilot, an R-FCH, and an R-SCH1. The R-SCH1 (W_2^4) is much wider than the Walsh 16 channels (W_0^{16} and W_4^{16}).



R-Pilot (W_0^{32}) R-FCH (W_4^{16}) Wide channel corresponds to R-SCH1 (W_2^4)

Figure 19. Code domain power for a signal with an R-Pilot, an R-FCH, and an R-SCH1 (W_2^4)

The code domain power measurement not only helps you verify that each Walsh channel is operating at its proper level, but also identify problems throughout the transmitter design, from the coding to the RF section. In particular, the level of the inactive channels can provide useful information about specific impairments [6]. The projection of the error signal over the code domain, known as code domain error, is of even more interest. You want the error power to be distributed through the code domain, rather than concentrated in a few codes, to avoid code-dependent channel quality variations. However, many transmitter impairments, such as amplifier compression and LO instability, cause uneven distribution of the error throughout the code domain. In these cases, energy is lost from the active channels and appears in related code channels in deterministic ways [1]. For this reason, it is useful to ensure that the code domain error is under a certain limit. The peak code domain error measurement (shown in figure 15b in combination with a composite rho measurement) indicates the maximum code domain error in the signal and to which code channel this error belongs.

Related to code domain power, IS-95 standards specify a pilot channel to code channel time tolerance and pilot channel to code channel phase tolerance for the BTS [1]. Since the cdma2000 MS has many similarities with a BTS, these tests will probably be part of the IS-2000 standard for MS. However, they are irrelevant if digital summing is used, since digital summing prevents delays and phase shifts between channels.

Apart from looking at the code domain power, it is useful to analyze a specific code channel. The following sections describe some analysis tools and how they can be applied. Figure 20 shows how the references for these measurements are calculated.

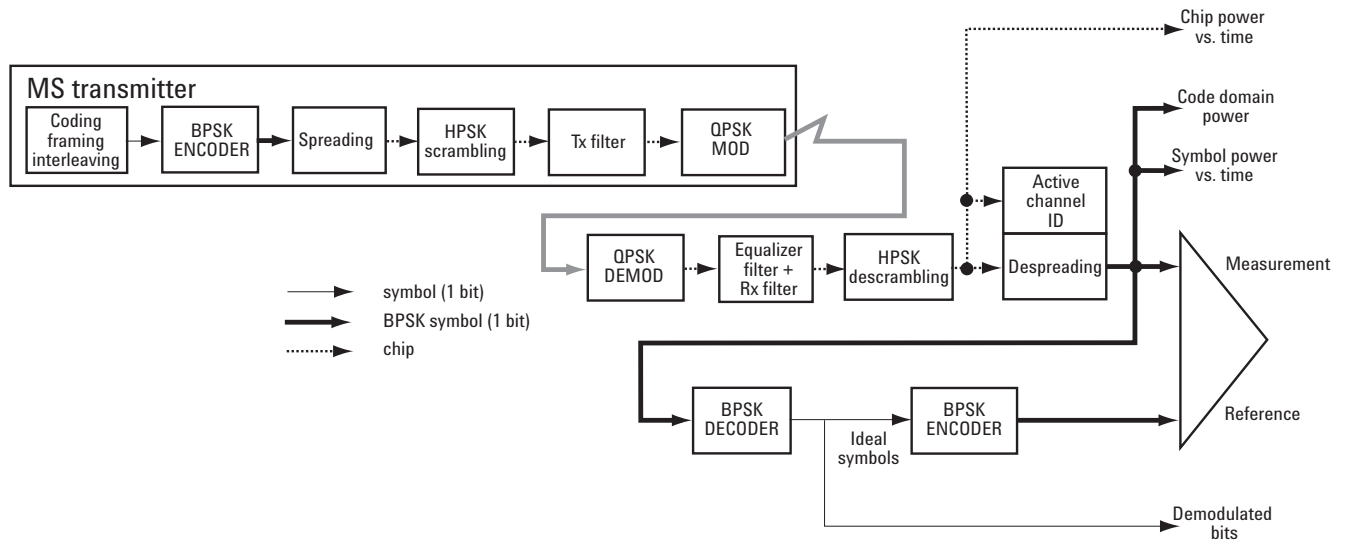

Figure 20. Process to calculate code domain power, symbol EVM, symbol power and chip power versus time, and the demodulated bits for a cdma2000 reverse link signal

2.2.4 Symbol EVM

By descrambling and despreading the signal, you can analyze the constellation for a specific code channel at the symbol level, even in the presence of multiple code channels. The measured signal is complex descrambled, despread, and BPSK decoded to symbols. The ideal symbols are then BPSK encoded to obtain the reference at the BPSK symbol level. This reference is then compared to the measured, despread symbols (figure 20).

An RF impairment that affects symbol EVM will also affect the composite EVM. For example, an amplifier compression problem will appear both in the composite EVM and in the symbol EVM measurement. However, because of the processing gain, symbol EVM will mute the impairment. So why use symbol EVM?

Symbol EVM provides the bridge between RF and the demodulated symbols. Since it includes the processing gain, it provides baseband engineers a measure of modulation quality closer to real-life performance. In this sense, you can think of it as the actual quality the user will experience in that channel (similar to the reciprocal of bit error rate (BER)).

The relationship between symbol EVM and chip EVM depends on the Walsh code length. For short Walsh code channels (less processing gain) chip modulation errors have a significant effect on symbol EVM. But for long code channels (more processing gain), chip modulation errors have little effect on symbol EVM. Therefore, there is a compromise between the data rate and the modulation quality. In this sense, symbol EVM is particularly useful to baseband DSP engineers to analyze how different impairments affect the quality of channels at different data rates. For example, figure 21 shows the cdma2000 code domain power measurement (bit reverse display) for a signal with an R-Pilot, an R-FCH, and an R-SCH1 (W_1^2). The signal suffers from high-frequency LO interference. Figure 21a shows the constellation and symbol EVM (around 19 percent) for the R-FCH (W_4^{16}) channel. Figure 21b shows that the higher data rate channel, R-SCH1 (W_1^2), suffers from a higher symbol EVM (around 28 percent).

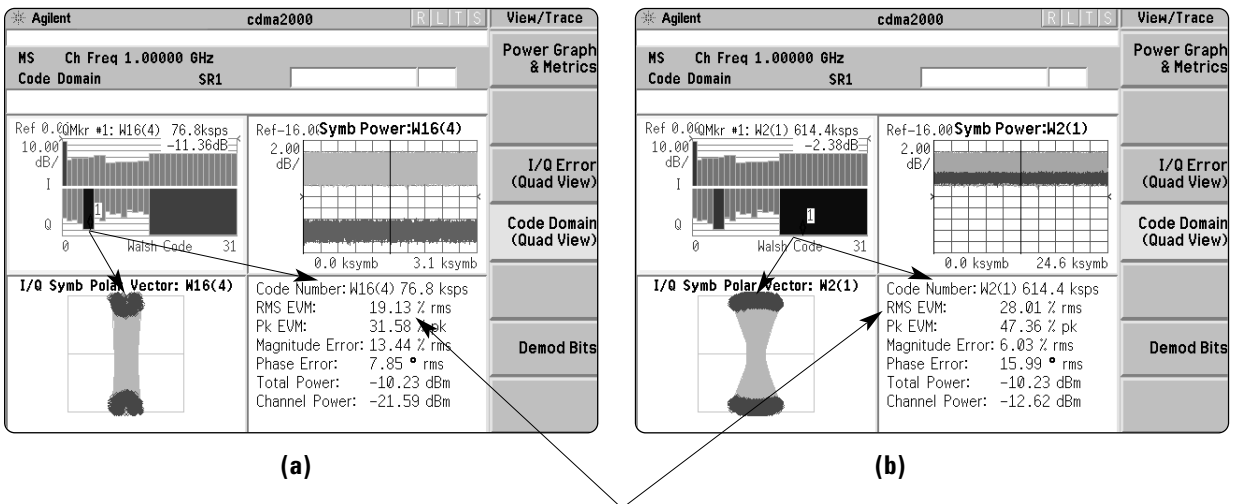

Impairment causes higher symbol EVM in high data rate channel

Figure 21. cdma2000 code domain power measurement (bit reverse display) for a signal with an R-Pilot, an R-FCH (W_4^{16}), and an R-SCH1 (W_1^2). Signal has a high-frequency LO interference problem. (a) Symbol EVM measurement for the R-FCH. (b) Symbol EVM measurement for the R-SCH1.

2.2.5 Symbol power versus time

Analyzing the power for a specific code channel versus time (or versus symbol) can be particularly useful to monitor the power and response of the MS power control system for different channels. For example, figure 22 shows a symbol power increase of .5 dB in the R-FCH, for the same signal used for figure 21, but with no impairments.

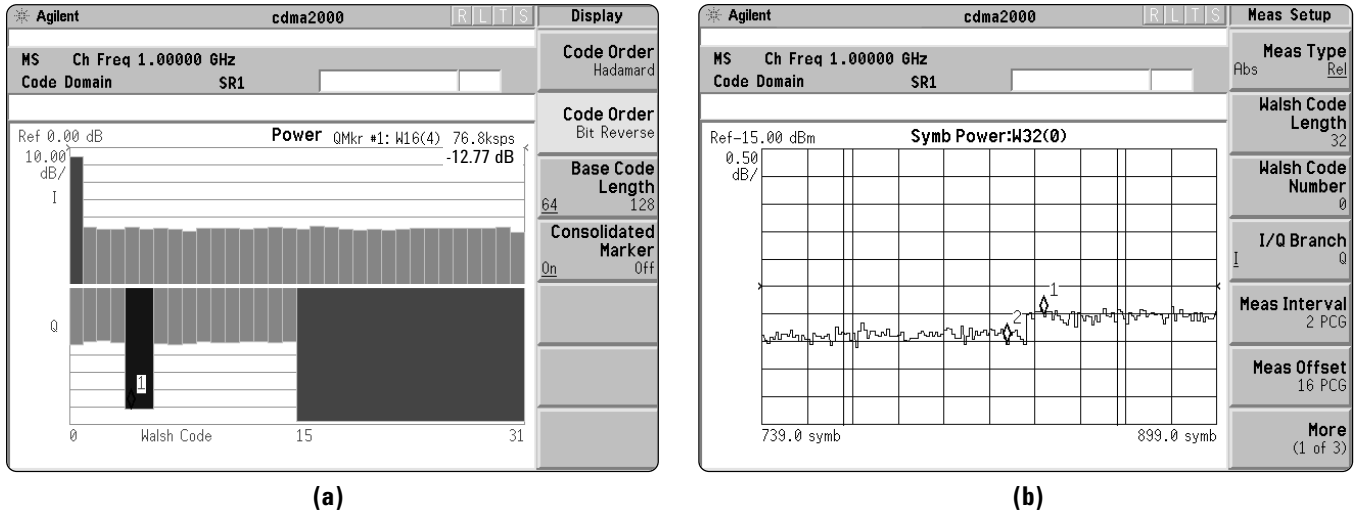

Figure 22. (a) cdma2000 code domain power measurement (bit reverse display) for a signal with an R-Pilot, an R-FCH (W_4^{16} at -12.77 dB), and an R-SCH1 (W_1^2 at -3.77 dB). (b) Symbol power versus time for the R-FCH.

Figure 23 shows the symbol power versus time in combination with the chip power for the signal versus time. This is particularly useful for system integrators to analyze the power amplifier response (ripple) to a series of power control commands.

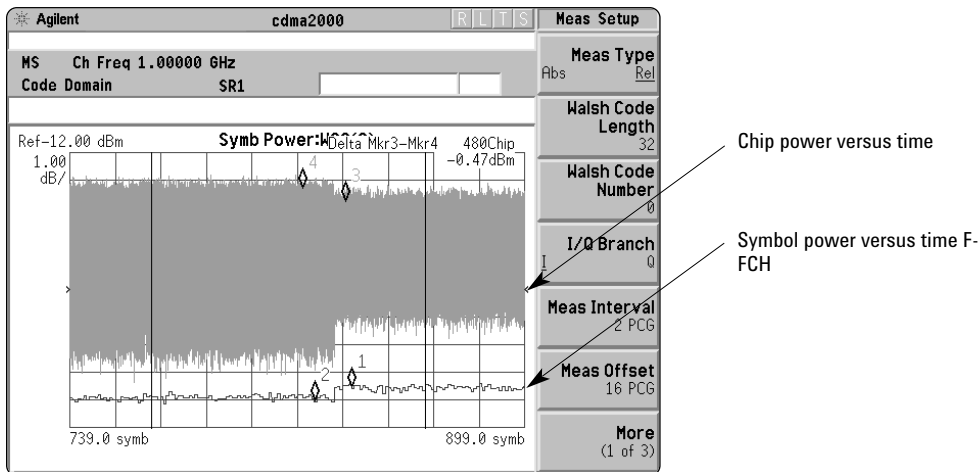

Figure 23. Chip power versus time for a signal with an R-Pilot, an R-FCH (W_4^{16} at -12.77 dB) and an R-SCH1 (W_1^2 at -3.77 dB), combined with symbol power versus time for the R-FCH

2.2.6 Demodulated bits

By obtaining the demodulated symbols after descrambling and despreading for each code channel, the correct symbol patterns can be verified. This is particularly important for the power control bits, since power control is absolutely critical to system performance. In cdma2000, the MS uses the R-Pilot to send power control bits to the BTS. The power control bits are multiplexed with the pilot data bits. Figure 24 shows the demodulated bits (symbols before de-interleaving and decoding) for the R-Pilot of a cdma2000 signal with the same channel configuration as in previous figures.

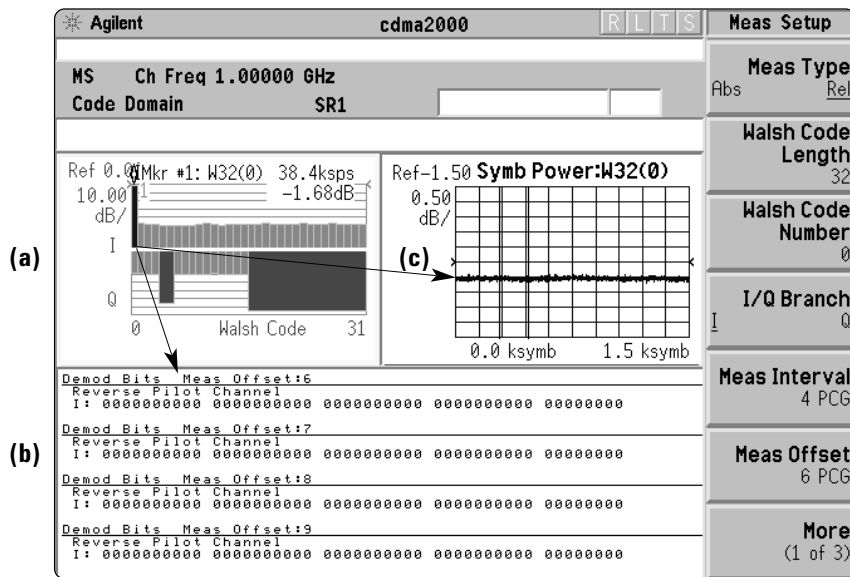

Figure 24. (a) cdma2000 code domain power measurement (bit-reverse display) for a signal with R-Pilot, an R-FCH (W_4^{16} at -12.77 dB), and an R-SCH1 (W_1^2 at -3.77 dB). (b) Demodulated bits for the R-Pilot. (c) Symbol power versus time for the R-Pilot.

Demodulated bits is an important troubleshooting tool for baseband engineers to identify coding, interleaving, and power control bit errors. In many cases it can help you clarify situations where the BTS and MS are having problems communicating with each other. Analyzing the demodulated bits may confirm whether the error is coming from the MS coding and interleaving or the BTS de-interleaving and decoding process.

2.3 Measuring receiver performance

Since the air interface for the cdma2000 forward link is similar to cdmaOne, the same issues and measurements for cdmaOne mobile receiver test apply to cdma2000. However, in cdma2000 the testing is complicated by a couple of factors that are fundamental for a 3G system: capability for variable data rates and higher capacity. The following sections describe how this impacts the mobile receiver test and what new source requirements may be needed to perform appropriate testing.

2.3.1 Performance tests at variable data rates

As seen earlier, cdma2000 uses different RCs and Walsh code lengths to accommodate the variable data rates. In order to demodulate a channel the MS receiver must identify the channel's data rate. The IS-2000 standard requires demodulation performance tests be made for a large number of channels at different RCs and data rates to ensure good receiver performance. This poses a challenge both in the time spent and source requirements for the test.

To perform these tests you need a source capable of simulating fully-coded forward link signals with channels at all possible RCs and data rates. You must be able to change parameters and input data. The best solution for this is to use a real-time cdma2000 generator, with which you can change the channel configuration and parameters to generate a new signal in a few seconds. (See appendix for information on available cdma2000 real-time generators.)

2.3.2 Quasi-orthogonal functions

High data rate channels occupy a lot of the BTS code space. There may be situations where a few users (or even a single user) transmitting data at high data rates use all the available codes. To obtain more code space, the IS-2000 standard specifies a new set of orthogonal codes to complement the existing Walsh codes. The new codes are known as quasi-orthogonal functions (QOF). The QOFs increase the code space at the expense of higher interference.

The receiver must be able to demodulate Walsh channels in the presence of QOF channel interference. Therefore, the receiver tester source must be able to generate cdma2000 channels spread with QOF codes.

Appendix: Agilent solutions for cdma2000 MS design and test

This section provides a list of Agilent's solutions that can help you develop and test your cdma2000 MS design.

Design software and simulation

The Agilent cdma2000 design library helps communication and RF system designers perform system-level tradeoff, requirement partitioning, and performance verification based on TIA IS-2000 standards. The library allows the simulation of key transmitter and receiver measurements such as error vector magnitude (EVM), adjacent channel power ratio (ACPR), bit error rate (BER) and frame error rate (FER). The library also helps component designers validate the performance of their subsystem against cdma2000 specifications.

The current release of the cdma2000 design library has gone through a major upgrade with addition of the following key features:

- upgraded to a more recent specification (IS-2000-A. 2000-10)
- includes more than 40 new models and more than 25 new designs

These designs are part of the new test and verification capability for base and mobile stations. The highlights of the new designs are:

- Base and mobile station transmitter
 - code domain power measurement
 - total mean transmit power
 - relative mean output power of code to pilot channel (reverse link)
 - pilot power
 - waveform quality (ρ)
 - conducted spurious emission
- Base and mobile station receiver
 - adjacent channel selectivity
 - reverse demodulation performance in AWGN channel
 - receiver spurious response attenuation
 - intermodulation spurious response attenuation
 - single tone desensitization

- single tone desensitization (with transmitter leakage)
- Signal source
 - transmit power spectrum and rho of forward pilot source
 - transmit power spectrum and the CCDF of the forward pilot source
 - transmit power spectrum, rho and the CCDF of reverse source
- BER validation
 - FER performance for forward traffic channel RC3 in AWGN channel
 - FER performance for reverse traffic channel RC3 in AWGN channel

For more information see

<http://contact.tm.agilent.com/tmo/eesof/products/e8877a-a.html>

Signal generation

The Agilent ESG RF signal generator¹ with the multicarrier cdma2000 option is capable of simulating statistically correct forward and reverse link cdma2000 signals for MS component and subsystem testing. An easy-to-use interface allows you to:

- select the spreading rate (SR1 or SR3)
- select from several predefined cdma2000 multi-channel signals
- use the table editor to fully configure a cdma2000 multi-channel signal per your requirements

The Agilent ESG RF signal generator with the fully-coded cdma2000 option is capable of simulating fully coded cdma2000 signals (SR1) for MS receiver test. Fully coded signals are ideal for conducting frame or BER tests to verify receiver performance. The cdma2000 personality is backward compatible with IS-95 systems using RC1 or RC2. The key features are:

- Fully coded channels including pilot, sync, paging, quick paging, fundamental, and supplemental traffic channels that support QOF and orthogonal channel noise simulator (OCNS). Signal configuration is simplified using the built-in table editor. Many parameters, including the power level for each channel, ISI filter type, PN offset, even second delay, and others, (depending upon channel type) can be modified.
- Paging: insert single messages into the built-in periodic paging stream (PPS) asynchronously.
- F-FCH: select the RC (1 to 5), data rate (full, half, one-quarter, or one-eighth), Walsh code, long-code mask, data source (this can be PN9, PN15, any 4-bit pattern, or a user file), frame offsets 0 to 15, and power control bit handling. Power control bit handling allows a ramp of 1 to 80 up or down for closed loop power control, plus all up or all down and supports QOFs 0 to 3.

Power meters and sensors

The Agilent EPM-P series power meters and E9320 peak and average power sensors provide peak, average and peak-to-average ratio power measurements on cdma2000 signals. Fast test times, with a measurement speed of up to 1,000 corrected readings per second, over the general purpose instrument bus (GPIB), help increase throughput to meet time-to-market and time-to-volume goals. The E9320 peak and average power sensors have a maximum video bandwidth of 5 MHz, ideal for cdma2000 power measurements.

EPM-P Analyzer software is provided on a CD-ROM, and is a PC based tool for pulse and statistical analysis. For cdma 2000, statistical analysis of the power distribution provides essential characterization to optimize system design, such as testing for amplifier compression.

1. The ESG family of RF signal generators consists of many different models to meet your specific signal generation needs. The E4438C is the newest high performance model that meets the demands of cdma2000 signal generation. It combines both the multicarrier and fully-coded cdma2000 options in a single package.

Recommended power meters and sensors for cdma2000 peak and average power measurements are:

- EPM-P series power meter E4416A, single channel
- EPM-P series power meter E4417A, dual channel
- E9323A peak and average power sensor, 50 MHz to 6 GHz, 5 MHz video bandwidth, -60 to +20 dBm.

All 8480 and E-series power sensors are compatible with the EPM-P series power meters.

For average power measurements only, the lower cost EPM series power meters and other E-series power sensors recommended are:

- EPM series power meter E4418B, single channel
- EPM series power meter E4419B, dual channel
- E9301A power sensor, 10 MHz to 6 GHz, -60 to +20 dBm
- E9301H power sensor, 10 MHz to 6 GHz, -50 to +30 dBm
- E9300B power sensor, 10 MHz to 6 GHz, -30 to +44 dBm

Other power sensors in the 8480 series are compatible with the EPM series power meters.

Power supplies

Agilent 66319B/D, 66321B/D single and dual DC output high performance power supplies combined with the 14565A Device Characterization Software provide very fast transient output response with a built-in advanced "DSP" based measurement system. They are designed for testing digital wireless appliances with the following functions:

- replace the main battery and power adapter
- emulate internal battery resistance
- emulate battery voltage response through very fast power supply output
- generate very low voltage drop in response to pulsed current demands
- measure battery current drains with very high accuracy (dc average, leakage, standby mode and talk mode)
- provide dual DC outputs with source/sink capability for testing and calibrating charger circuitry
- simplify for easy power supply control and measurement setup with no programming required using Graphical User Interface software

Signal analysis

This table provides the list of Agilent signal analyzers and their cdma2000 measurement capabilities for MS transmitter test (as of November 2001).

Table 1. Agilent signal analysis capabilities for cdma2000 SR1

cdma2000		Agilent signal analyzers				
		Vector signal analyzers			Spectrum analyzers	
Measurements		E4406A VSA transmitter tester ¹	89400A series vector signal analyzer ²	89600 vector signal analyzer ²	PSA series spectrum analyzer ¹	ESA-E series spectrum analyzer ¹
Channel power		●	● ³	● ³	●	●
Occupied bandwidth		●	● ³	● ³	●	●
In-band emissions	ACPR	●	● ³		●	●
	In-band spurious	●	● ³		●	● ³
Out-of-band emissions (spurious/harmonics)					● ⁵	● ³
Peak/average power ratio		●	●	●	●	●
CCDF		●	●	●	●	●
Modulation quality	Rho	●	● ⁴	●	●	
	QPSK EVM	●	●	●	●	●
	Composite EVM	●		●	●	
	I/Q offset	●	●	●	●	
	Frequency accuracy	●	●	●	●	
	Code domain power	●		●	●	
	Symbol EVM	●		●	●	
	Symbol power vs. time	●		●	●	
	Composite chip power vs. time	●		●	●	
Demodulated bits	●		●	●		

Notes:

1. Measurement preconfigured for cdma2000.
2. Some measurements pre-configured for cdma2000 (or cdmaOne). Parameters for other measurements must be set up manually as indicated.
3. Manual measurement (no automatic spurious search or ACPR measurement).
4. There are several interpretations of rho. The 89400 series vector signal analyzers can make the rho measurement with certain assumptions.
5. Manual measurement.

cdma2000 mobile test application for the Agilent 8960 Series 10 wireless communications test set

Agilent's cdma2000 mobile test solution provides the essential RF parametric test and call processing capabilities you will need to verify the quality and RF performance of your cdma2000 phones, allowing you to finalize product designs and time-to-volume. This test solution provides the capability to perform extremely fast cdma2000 transmitter and receiver tests using call processing to establish a traffic or fundamental channel using standard test service options or in test modes for mobile phone calibration.

Transmitter tests:

- maximum power
- minimum power
- multi-coded waveform quality (composite rho and EVM)
- hand-off waveform quality
- open loop power accuracy
- open loop power calibration
- access probe power
- code-domain power

Receiver tests:

- sensitivity
- dynamic range
- demodulation with additive white Gaussian noise (AWGN)

The fully coded, cdma2000 forward-link emulation supports RCs 1 through 5 and all supplemental channel data rates associated with those configurations. Comprehensive signal generation capability includes the cdma2000 channels (F-pilot, F-sync, F-paging, F-FCH, F-SCH, F-OCNS), cdma2000 modulation (parallel BPSK for pilot, sync, and paging channels and QPSK for F-FCH), and an AWGN source (1.8 MHz minimum bandwidth). Flexible user control of the forward link emulation is provided through easy-to-use front panel control and remote general purpose instrument bus (GPIB).

Because this cdma2000 test solution is based on the high-performance Agilent 8960 Series 10 test set, you gain the additional benefits of extremely fast measurement speed, ease of programming, accuracy, reliability, and worldwide service and support. These proven features will help you shorten test development time, increase throughput, and minimize support costs. The 8960 Series 10 is also a powerful multi-format test platform currently offering test applications for global system for mobile communication (GSM), general packet radio service (GPRS), and advanced mobile phone system (AMPS)/IS-136 giving you industry leading manufacturing flexibility.

Instruments used for measurement examples

The measurement examples and screen images in this application note were obtained using the following instruments:

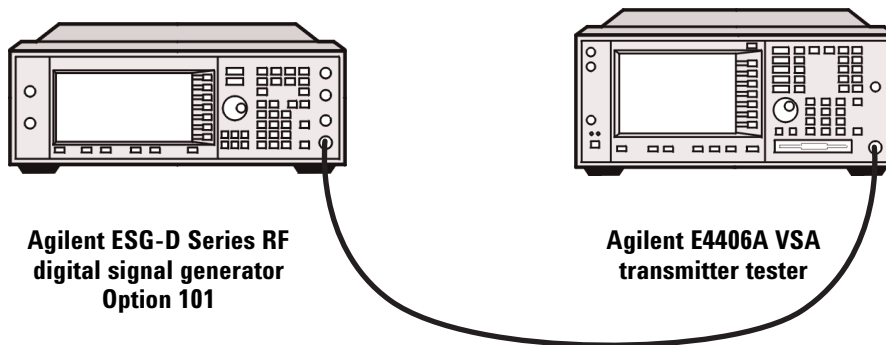

Acronym glossary

2G	Second Generation
3G	Third Generation
3GPP2	Third-Generation Partnership Project 2
ACP	Adjacent Channel Power
ACPR	Adjacent Channel Power Ratio
AMPS	Advanced Mobile Phone System
ARIB	Japanese Association of Radio Industries and Businesses
AWGN	Additive White Gaussian Noise
BPSK	Binary Phase Shift Keying
BTS	Base Transceiver Station
CCDF	Complementary Cumulative Distribution Function
CDMA	Code Domain Multiple Access
cdmaOne	Name identifying the EIA/TIA standard (commonly referred to as IS-95) for 2G
cdma2000	Name identifying the EIA/TIA standard (IS-2000) for 3G
CRC	Cyclic Redundancy Check
DS	Direct Sequence
DSP	Digital Signal Processing
EVM	Error Vector Magnitude
F-DCCCH	Forward Dedicated Control Channel
FER	Frame Error Rate
F-FCH	Forward Fundamental Channel
FIR	Finite Impulse Response
F-Paging	Forward Paging
F-Pilot	Forward Pilot
F-SCCH	Forward Supplemental Code Channel
F-SCH	Forward Supplemental Channel
F-Sync	Forward Sync
F-Traffic	Forward Traffic
GMSK	Gaussian Minimum Shift Keying
GPIB	General Purpose Instrument Bus
GPRS	General Packet Radio Service
GSM	Global System for Mobile Communications
GPS	Global Positioning System
HPSK	Hybrid Phase Shift Keying
IF	Intermediate Frequency
IMT-2000	International Mobile Telecommunications-2000
I/Q	In-phase/Quadrature
IS-136	Interim Standard for US Time Domain Multiple Access
IS-2000	EIA/TIA Interim Standard 2000 (see cdma2000)
IS-95	Interim Standard for US Code Division Multiple Access
LO	Local Oscillator
LSB	Least Significant Bit
MS	Mobile Station
MSB	Most Significant Bit
OCNS	Orthogonal Channel Noise Simulator
OCQPSK	Orthogonal Complex Quadrature Phase Shift Keying
OQPSK	Offset Quadrature Phase Shift Keying
OVSF	Orthogonal Variable Spreading Factor
PSK	Phase Shift Keying
QAM	Quadrature Amplitude Modulation
QOF	Quasi-Orthogonal Functions
QPSK	Quadrature Phase Shift Keying
R&D	Research and Development
RC	Radio Configuration
RF	Radio Frequency
R-CCCH	Reverse Common Control Channel
R-DCCCH	Reverse Dedicated Control Channel
R-EACH	Reverse Enhanced Access Channel
R-FCH	Reverse Fundamental Channel
RMS	Root Mean Square
R-Pilot	Reverse Pilot
R-SCH	Reverse Supplemental Channel
SR	Spreading Rate
TIA	Telecommunications Industries Association
TTA	Korean Telecommunications Technology Association
TTC	Telecommunication Technology Committee
W-CDMA	Wideband-Code Division Multiple Access (3G system)
UE	User Equipment

For more information regarding these acronyms and other wireless industry terms, please consult our wireless dictionary at www.agilent.com/find/wireless.

References

- [1] *Understanding CDMA Measurements for BSs and Their Components*, Application Note 1311, literature number 5968-0953E.
- [2] Ken Thompson, "Concepts of cdma2000," Wireless Symposium, 1999.
- [3] *HPSK Spreading for 3G*, Application Note 1335, literature number 5968-8438E.
- [4] *Designing and Testing W-CDMA User Equipment*, Application Note 1356, literature number 5980-1238E.
- [5] *Characterizing Digitally Modulated Signals with CCDF Curves*, Application Note, literature number 5968-6875E.
- [6] *Testing and Troubleshooting Digital RF Communications Transmitter Designs*, Application Note 1313, literature number 5968-3578E.

Related literature

- 89400 Series Vector Signal Analyzers*, literature number 5965-8554E.
- E4406A Vector Signal Analyzer Brochure*, literature number 5968-7618E.
- EPM Series Power Meters*, literature number 5965-6380E.
- EPM-P Series Power Meters E9320 Family of Peak and Average Power Sensors Product Overview*, literature number 5980-1471E.
- ESA-E Series Spectrum Analyzers*, literature number 5968-3278E.
- ESG Series RF Digital and Analog Signal Generators*, literature number 5968-4313E.
- ESG Signal Generator/Option 201 Real-Time IS-2000 Mobile Receiver Measurements*, Product Note, literature number 5968-9551E.
- Considerations When Selecting a System Power Supply for Mobile Communications Device Testing*, Application Note 1310, literature number 5968-2424E.
- Designing and Testing cdma2000 Base Stations*, Application Note 1357, literature number 5980-1303E.
- Designing and Testing W-CDMA Base Stations*, Application Note 1355, literature number 5980-1239E.
- Fundamentals of RF and Microwave Power Measurements*, Application Note 64-1B, literature number 5965-6630E.
- Generating Custom, Real-World Waveforms for 3G Wireless Applications*, Application Note 1298, literature number 5968-8388E.
- Testing and Troubleshooting Digital RF Communications Receiver Designs*, Application Note 1313, literature number 5968-3579E.
- Wide-Range Sensor Gauges Power of Complex Signals* (written by Ron Hogan and originally printed in *Microwaves & RF*, September 1999), literature number 5968-8750E.
- E4440A PSA Series Performance Spectrum Analyzers*, literature number 5980-1283E.
- 89600 Series Wide-Bandwidth Vector Signal Analyzers*, literature number 5980-0723E.
- cdma2000 Design Library*, literature number 5968-8158E.
- 8960 Series 10 Wireless Communication Test*, literature number 5968-7876E.

By internet, phone, or fax, get assistance with all your test & measurement needs

Online assistance:
www.agilent.com/find/assist

Phone or Fax
United States:
(tel) 1 800 452 4844

Canada:
(tel) 1 877 894 4414
(fax) (905) 282-6495

China:
(tel) 800-810-0189
(fax) 1-0800-650-0121

Europe:
(tel) (31 20) 547 2323
(fax) (31 20) 547 2390

Japan:
(tel) (81) 426 56 7832
(fax) (81) 426 56 7840

Korea:
(tel) (82-2) 2004-5004
(fax) (82-2) 2004-5115

Latin America:
(tel) (305) 269 7500
(fax) (305) 269 7599

Taiwan:
(tel) 080-004-7866
(fax) (886-2) 2545-6723

Other Asia Pacific Countries:
(tel) (65) 375-8100
(fax) (65) 836-0252
Email: tm_asia@agilent.com

Product specifications and descriptions in this document subject to change without notice.

Copyright © 2001 Agilent Technologies
Printed in U.S.A. December 17, 2001
5980-1237E



Agilent Technologies